



casagrande

C16^{XP}

HYDRAULIC CRAWLER DRILL

PERFORATRICE IDRAULICA

TECHNICAL SPECIFICATIONS

DATI TECNICI



UNDERCARRIAGE		CARATTERISTICHE CARRO		
Overall width of undercarriage	Larghezza sottocarro	8.2 - 12.14 ft	2500 - 3700 mm	
Track shoes width	Larghezza pattini	23.62 in	600 mm	
Overall track length	Lunghezza cingoli	17.76 ft	4500 mm	
Travel speed	Velocità di traslazione	1.1 mph	1,5 km/h	
Max. gradeability	Pendenza max. superabile	20° / 37%	20° / 37%	
Ground pressure	Pressione specifica al suolo	9.58 PSI	67 kPa	
Swing drive	Rotazione torretta	360°	360°	
ENGINE	MOTORE	CUMMINS QSB 6.7		
Power at 2200 rpm	Potenza a 2200 giri	EU Stage IIIB/IV - US EPA TIER IVi/IVf - 260 HP 194 kW		
Fuel tank capacity	Capacità serbatoio gasolio	105 gal	400 l	
Hydraulic oil tank capacity	Capacità serbatoio olio idraulico	159 gal	600 l	
MAST	MAST	18500		
Mast length	Lunghezza mast	60.7 ft	18500 mm	
Stroke of rotary head	Corsa testa di rotazione	52.5 ft	16000 mm	
Extraction force	Forza di estrazione	33,720 lbf	150 kN	
Crowd force	Spinta sull'utensile	33,720 lbf	150 kN	
CLAMPS	MORSE	M4/M4S	M5/M5S	M6/M6S
Diameter	Diametro	60 ÷ 305 mm	90 ÷ 406 mm	152 ÷ 508 mm
		2.36 ÷ 12 in	3.54 ÷ 15.98 in	5.98 ÷ 20 in
Clamping force	Forza di chiusura	250 kN	283 kN	283 kN
		56,200 lbf	63,620 lbf	63,620 lbf
ROTARY HEAD	TESTA DI ROTAZIONE	T20 EP	T2500 EP	T3000 EP
Max. torque	Coppia max.	15200 Nm	20000 Nm	30000 Nm
		11,210 lbf-ft	14,750 lbf-ft	22,130 lbf-ft
Max. speed	Giri max.	52 ÷ 400 rpm	0 ÷ 220 rpm	0 ÷ 160 rpm
DIMENSIONS AND WEIGHT	INGOMBRI E PESO			
Length	Lunghezza	44.62 ft	13600 mm	
Width	Larghezza	8.36 ft	2550 mm	
Height	Altezza	10.56 ft	3220 mm	
Weight of rig *	Peso attrezzatura *	~ 34 / 35.3 ton		~ 31 / 32 t
* Depending on mounted equipment		* Dipende dall'allestimento montato		

OPTIONALS

OPZIONI

Diesel engine 214 HP / 295 HP	Motore diesel 160 kW / 220 kW
Rotary head type T5000	Testa di rotazione T5000
Double rotary head - Hammers	Doppia testa di perforazione - Martelli esterni
Hydraulic chuck P114 - P200	Mandrino P114 - P200
Jet system - with time or distance control	Impianto jet induttivo o temporizzato
2 rods loader vertical use Ø max. 140 mm	Caricatore 2 aste per uso verticale Ø max. 140 mm
6 rods carousel rods	Caricatore 6 aste
Auxiliary crane	Gru ausiliaria
A2 type hydraulic service winch; line pull 20 kN	Argano di servizio A2; tiro 20 kN
Flushing pump	Pompa acqua
Foam pump	Pompa schiumogeni
Mud pump	Pompa fanghi

DIMENSIONS

DIMENSIONI

C16^{XP}
HYDRAULIC CRAWLER DRILL

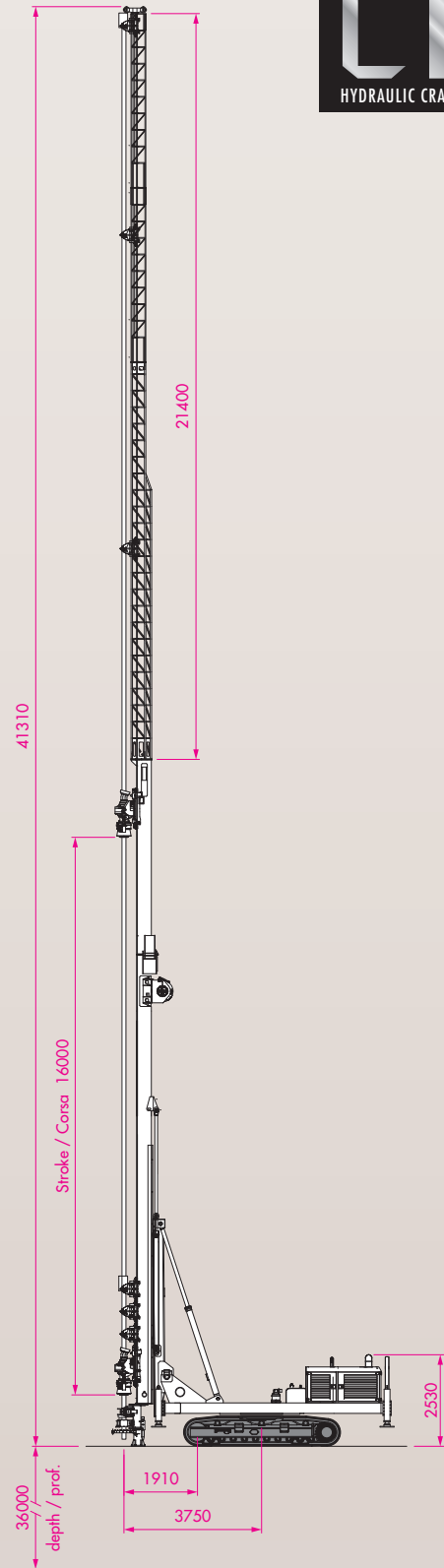
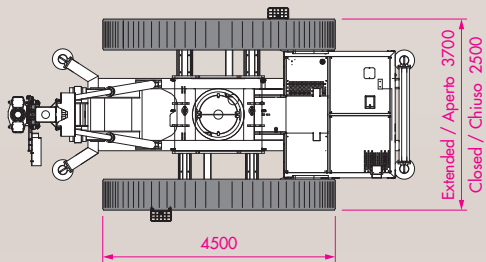
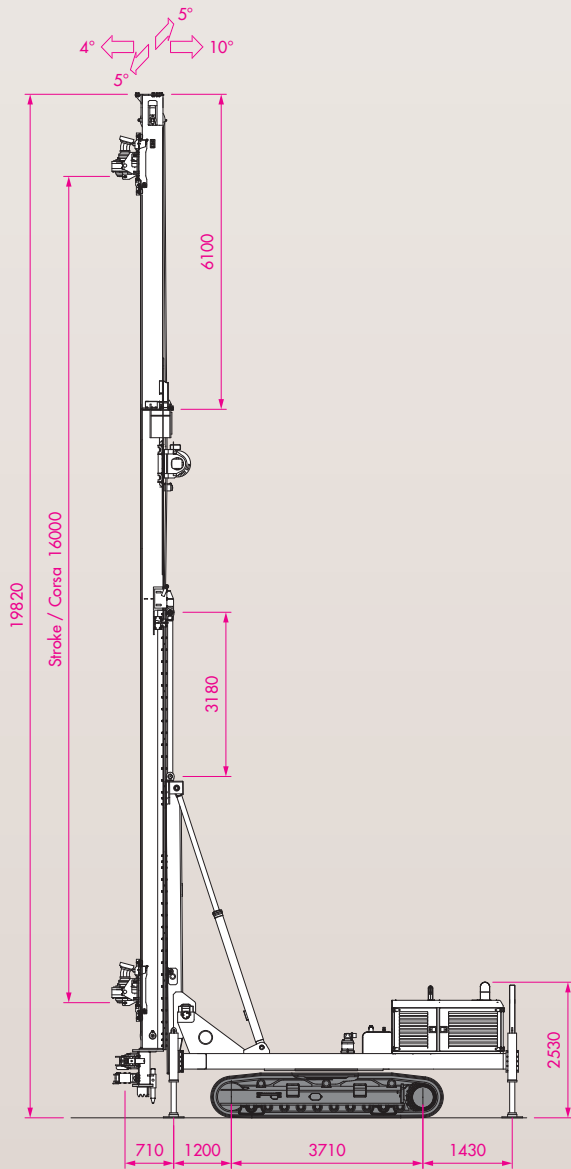

TRANSPORT DIMENSIONS

DIMENSIONI DI TRASPORTO

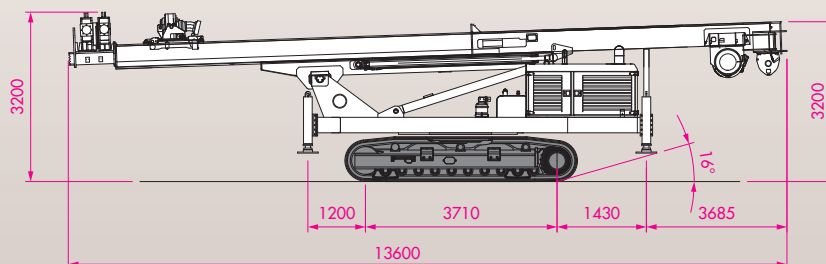

CASAGRANDE CRAWLER DRILLS RANGE

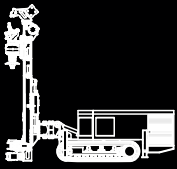

C2E

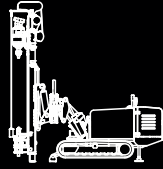

C3XP

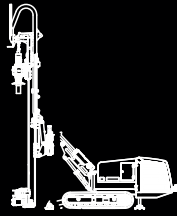

C5XP

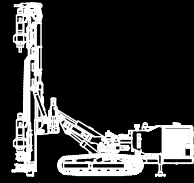

C5SXP

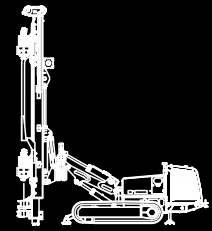

C6XP

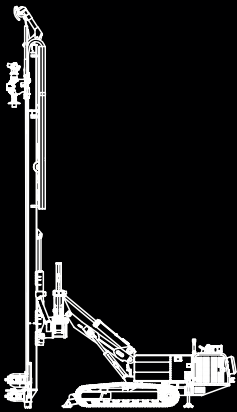

C7XP

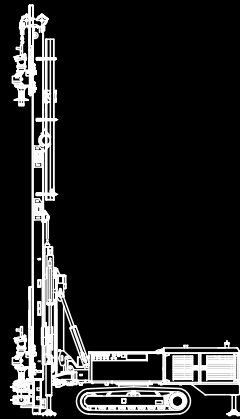

C8XP

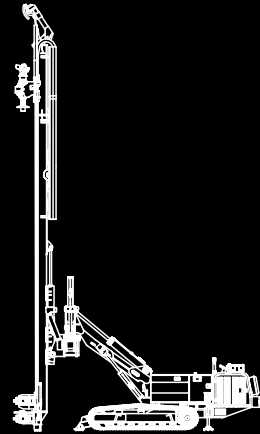

C9XP

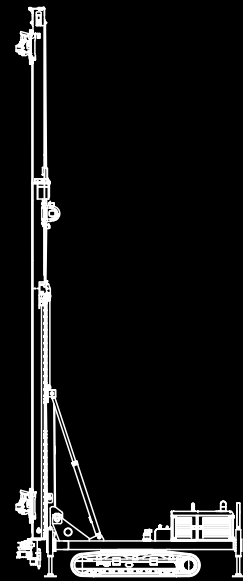

C16XP

All data contained in this brochure are indicative and does not take power losses into account. All data can be changed without notice.
Tutti i dati riportati su questo catalogo sono indicativi e non considerano perdite di carico. Tali dati possono variare senza preavviso.



casagrande

CASAGRANDE S.P.A.

Via A. Malignani, 1 • IT 33074 Fontanafredda • Pordenone • Italy
Tel. (+39) 0434 9941 • Fax (+39) 0434 997009
www.casagrandegroup.com • info@casagrandegroup.com

