



**casagrande**

**FD**

HYDROMILLS

FRESE IDRAULICHE



The hydromills are designed by Casagrande to match today's demands of diaphragm wall construction. Whenever the challenge of difficult soil condition, high productivity and shear accuracy are made in diaphragm walling, the Hydromills can cope.

#### **Versatility**

Whether in hard or soft soils, a choice of cutters is available to match every condition and demands of different wall width can be easily met, simply by changing the cutter wheels and the interchangeable guides. All models of the hydromills are designed to work on the principle of reverse circulation. Cutting chains are used enable the equipment to cut through hard strata, to guarantee the cut throughout the wall width and to provide better joints and excellent interlocking.

#### **Performance**

The hydromills utilizes a wealth of engineering expertise gained by Casagrande in many years of geotechnical available for the application of electronics to record depth, verticality and cutting force and to provide with instant information to control performance and maximize on production. The all-round ruggedness of hydromills are complemented by attention to details. The suspension of the hose reels by automatic winches and the fitting of a powerful flushing pump to remove cuttings.

# casagrande



# CASAGRANDE HYDROMILL ASSEMBLY

The equipment consists of a heavy steel frame with two drive gears, attached to its lower section, which rotate in opposite directions around horizontal axes. The soil, or rock, is "milled" by the cutting wheels from the bottom of the trench and continuously moved, mixed with slurry, and removed by a powerful flushing pump.

## Frame

Manufactured in heavy duty steel structure consists in the milling unit - lower section - which contains the motors, chain transmission system, excavating wheels and the slurry pump. The guide - upper section - which contains the control instrumentation and the verticality control steering plates.

## Steering plates

6 hydraulically-driven steering plates to correct verticality at the excavation stage. The steering plates have 4 work positions and are mounted in the upper section of the hydromill to maximise precision and effectiveness of operation.

## Guides

These are elements mounted on the frame to guide it during excavation work. Their thickness varies according to the dimensions of the panel to be built.

## Sensor Box

Accommodates the control instrumentation and the sensors for reading the hydromills' verticality.

## Compensators

These are hydraulic accumulators that guarantee balance between the external pressure exercised by excavation fluids at considerable depths and the inner pressure of the hydraulic components' lubrication.

## Mud Pump

The centrifugal pump sucks the excavated slurry mixed with the working fluids and pumps it to the separation plants. The pump's main parts are made in wear-proof material to maximise their durability. It is driven by a hydraulic motor that assures high prevalence and flow capacity.

## Hydraulic motors

Two radial piston motors transform the hydraulic power into torque and rotation speed. The absence of gear-motors increases the system's mechanical efficiency. Their position is such that they are directly subjected to the induced stresses during excavation stages.

## Chain

Transmits the motion of the hydraulic motors to the milling wheels and implements the joint between primary and secondary panels. On each chain element are mounted excavation teeth that guarantee "full excavation face".

## Tensioning system

Two independent hydraulic cylinders guarantee the tensioning of the chain for a correct transmission of the motion from the hydraulic motors to the excavating elements.

## Suction box

This is the point from which the suction of the excavated material takes place, entering the piping through specific suction holes.

## Wheels

Excavation units consisting of a hub on which are mounted the wheels. Driven by the chains that move the toothed wheels to transmit torque and speed. They are available in the standard and heavy duty versions according to the characteristics required by the worksite's geology and by the excavation depth.



- 1. MILL'S BODY
- 2. CHAIN
- 3. STEERING PLATES
- 4. CHAIN DETAIL
- 5. MUD PUMP
- 6. WHEELS
- 7. SUCTION BOX

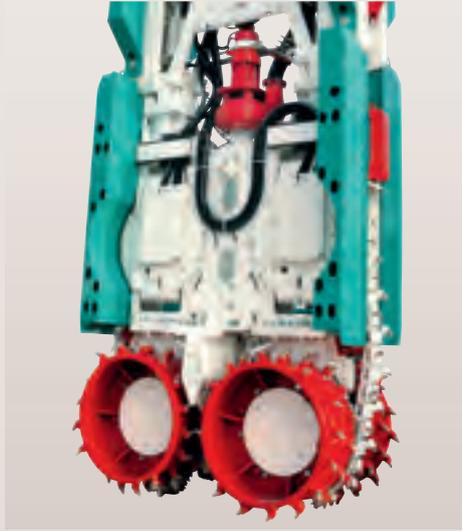

1.



2.



3.



4.



6.



5.



7.

# CASAGRANDE HYDROMILLS

## FD60

The FD60 is the model that suits the widest range of requests for special foundations. A version is available with special motors to increase the wheels torque.

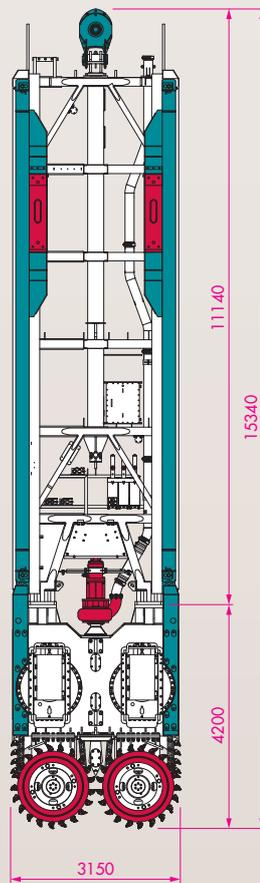
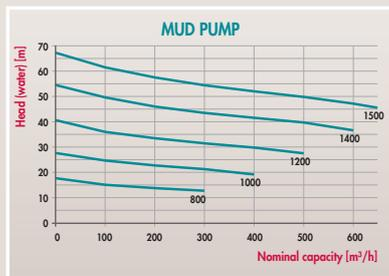
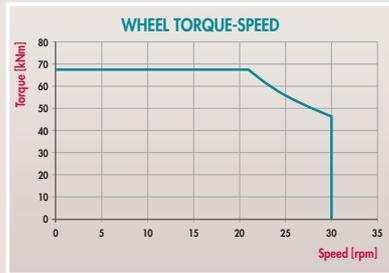

## FD100

The FD100 is designed with heavy duty wheel assembly and special hydraulic motors to deal with very thick diaphragms and under very demanding ground conditions.

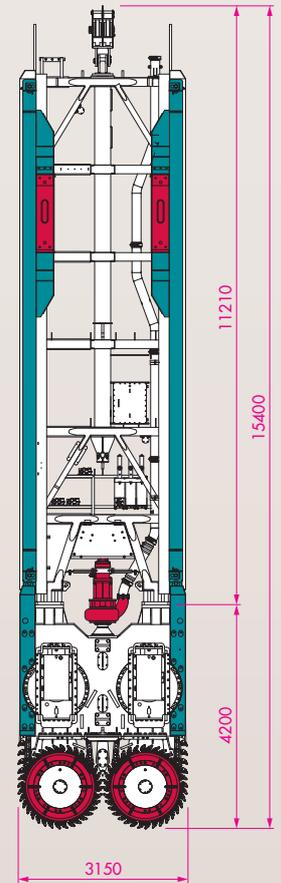
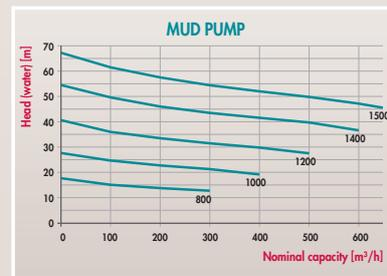

Length of trench	mm	3150
Width of trench	mm	700 * ÷ 1200
Torque at wheel axle	kNm	2 x 67
Wheel speed	rpm	0 ÷ 30
Suction pump	m³/h	450
Verticality control	X-axis	wheels + n°2 steering plates
	Y-axis	n°4 steering plates
Weight	t	33 ÷ 37

\* 660 with special mud pump

Length of trench	mm	3150
Width of trench	mm	800 ÷ 1500 *
Torque at wheel axle	kNm	2 x 99
Wheel speed	rpm	0 ÷ 21
Suction pump	m³/h	450
Verticality control	X-axis	wheels + n°2 steering plates
	Y-axis	n°4 steering plates
Weight	t	38 ÷ 45

\* 1800 with special arrangement

## FIELD OF APPLICATION

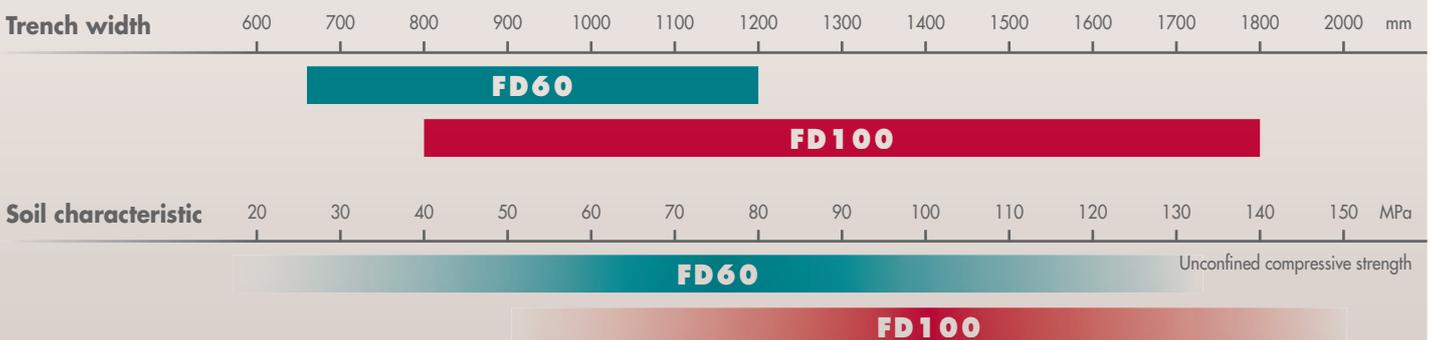



# FD60 - CRANE ARRANGEMENTS

## Crane

The hydromill is suspended from the crane's winches, while the hydraulic hoses and debris pipe are supported by the two idler wheels activated by two independent tensioning systems. According to the length of the lattice boom, different excavation depth can be managed.

## Crane Hose Reels

The hydromill is suspended from the crane's winches while two winders hold the hydraulic hoses and debris pipe. Each winder is activated by an independent hydraulic circuit in order to adjust the tensioning according to the depth to be dealt with. This configuration allows the reaching of considerable excavation depths with minimum boom length.

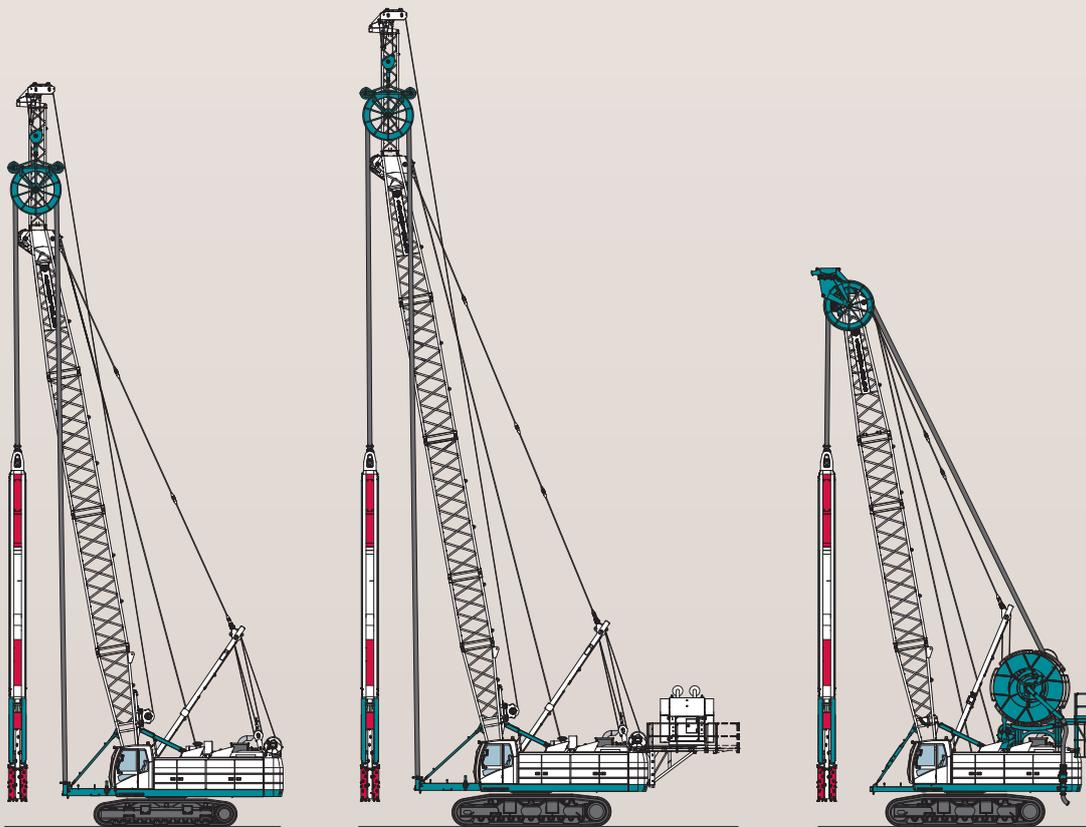

## FD • Crane arrangement

Base carrier		C850			C900				C900
Hose tensioning system		Winches			Winches				Hose reels
Depth	m	46	36	30	64*	52	42	30	100
Boom length	m	24	24	21	33	27	27	21	21
Jib extension	m	5	-	-	5	5	-	-	-
Approx. weight	t	130	129	128	154	142	141	150	155
Installed power	kW	480							
Power pack additional **	kW	194							

\* Special configuration

\*\* The additional power pack powers the mud pump, and allows a productivity increase and to work under extreme environmental conditions

# FD100 - CRANE ARRANGEMENTS

## Crane

The hydromill is suspended from the crane's winches, while the hydraulic hoses and debris pipe are supported by the two idler wheels activated by two independent tensioning systems. According to the length of the lattice boom, different excavation depth can be managed.

## Crane Hose Reels

The hydromill is suspended from the crane's winches while two winders hold the hydraulic hoses and debris pipe. Each winder is activated by an independent hydraulic circuit in order to adjust the tensioning according to the depth to be dealt with. This configuration allows the reaching of considerable excavation depths with minimum boom length.

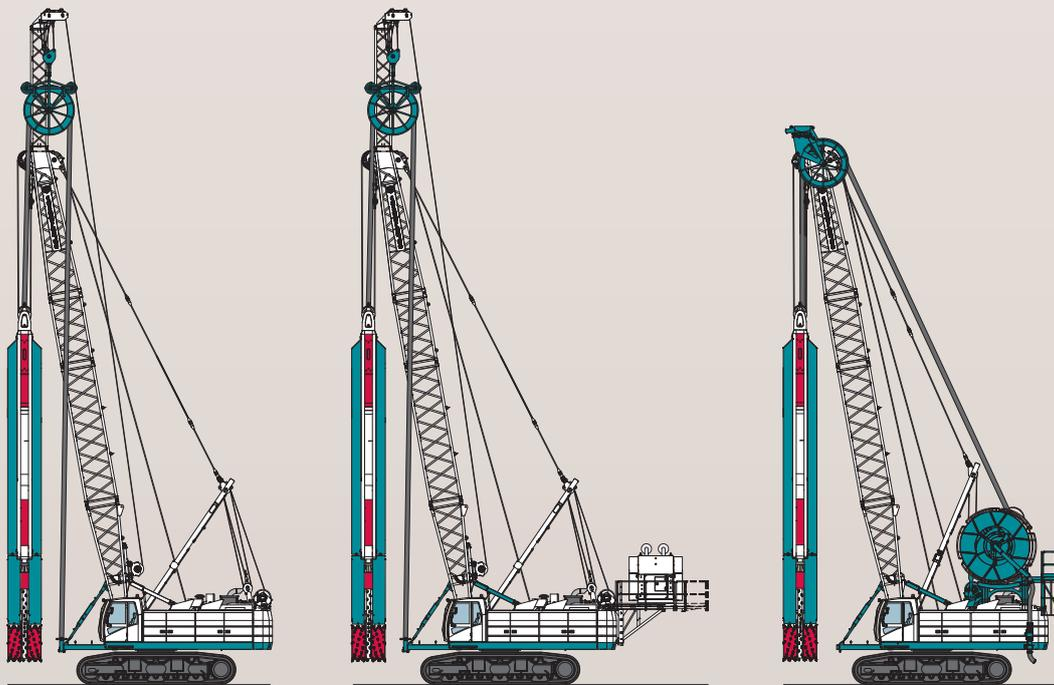

## FD • Crane arrangement

Base carrier		C900		C900	
Hose tensioning system		Winches		Hose reels	
Depth	m	52*	40	30	100
Boom length	m	27	21	21	21
Jib extension	m	5	5	–	–
Approx. weight	t	162	150	149	163
Installed power	kW			480	
Power pack additional **	kW			194	

\* Special configuration

\*\* The additional power pack powers the mud pump, and allows a productivity increase and to work under extreme environmental conditions

# CUTTING TEETH FOR WHEELS AND CHAIN

## Type of teeth available

According to ground characteristics, two typologies of cutting tools are available:

- teeth for rock and hard rock
- teeth soil and medium rock

For their dimensions and sturdiness, teeth for hard rock are always suitable for mounting on the chain elements.

The teeth are arranged in such a way as to cover the entire excavation surface and to convey the excavated material towards the suction box.

The position and inclination of each tooth assures the best cutting angle when in contact with the excavation material.

## HARD ROCK TEETH

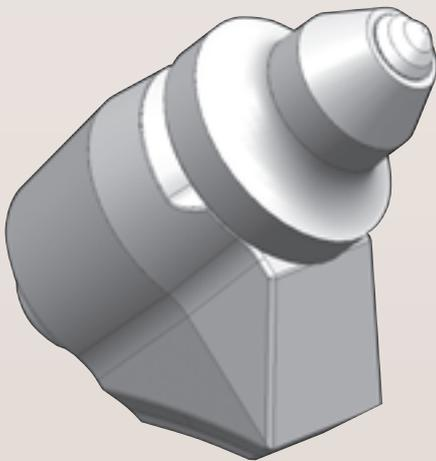

## SOIL AND MEDIUM ROCK

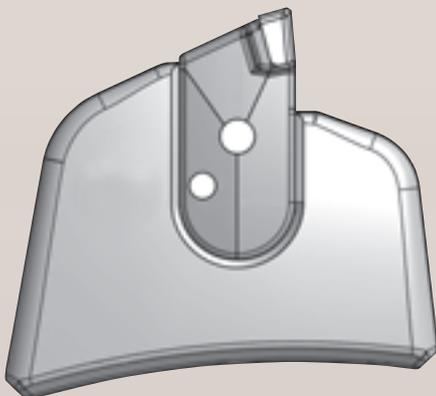



# FULL EXCAVATION FACE

The massive weight of the transmission motors and the lower blocks supporting the wheels concentrated in the lower part of the Hydromill frame, plus the utilization of the transmission chains' system insure the distribution of the weight of the machine in the entire width of the excavation.

The operator then, managing the "balance" of the weight of the rig will use the hydromill as a "reverse pendulum" system controls the verticality while optimizing production.

The configuration of the wheels teeth together with the position of the chains' teeth are designed to insure the cover of the entire trench section to have the FULL EXCAVATION FACE - and the proper transfer of the entire weight of the rig during excavation.



# JOINT FORMATION

Based on the excavation's depth specified, the project geology, the site logistic and "sensibility" the dimensions of the primary panels can range from the minimum 3150 mm (single byte) to a 7600 mm length (triple byte).

The panels' joints are formed without the use of end-stops while instead "milling" a portion of the concrete on the primary panels. The thickness of the concrete "milled" is based on the required excavation's depth and the capacities of the vertically recording system.

Because of the use of the "transmission chains technology" the Casagrande hydromills can create, during the installation of the secondary panels, a concrete joint system that produce, above the standard "grooved" joint a "key" extended into the primary panel.

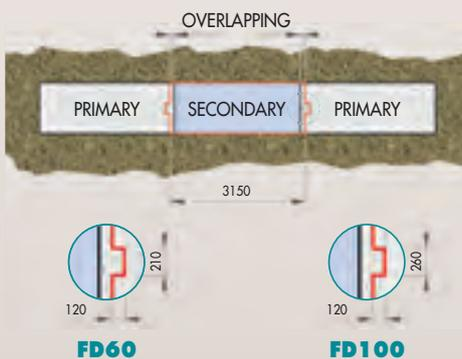

# PANELS INSTALLATION

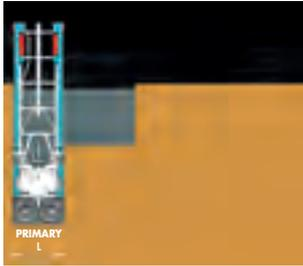

1. Pre-excitation (4-5 m) and excavation of primary panel

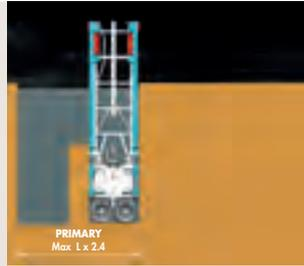

2. Excavation of second byte of primary panel

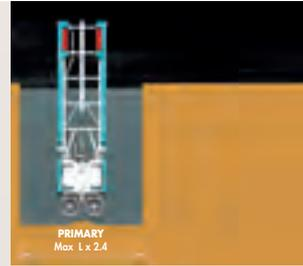

3. Excavation of middle byte of primary panel

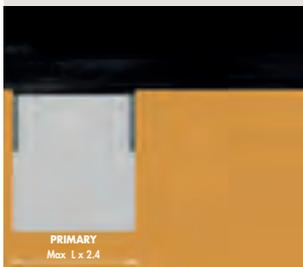

4. Installation of reinforcement and concreting

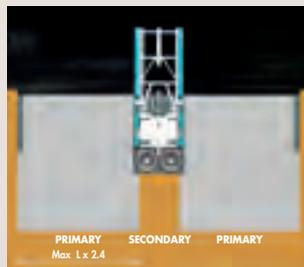

4. Excavation of secondary panel

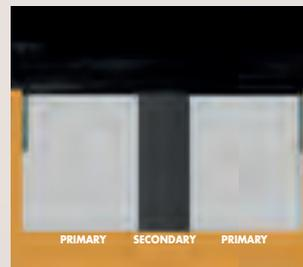

4. Installation of reinforcement and concreting



# INSTRUMENTATION

## Operator's cabin

The control instrumentation, installed in the operator's cabin, allows checking of the correct operation of all basic machine functions and those of the hydromill. Over and above the basic machine controls, there is a simple panel of controls dedicated to hydromill control.

## 12" display

The 12" colour touch screen display allows settings and provides information about the machine condition; moreover it allows and assists fault diagnostics.

All machine functions are controlled by a PLC network.

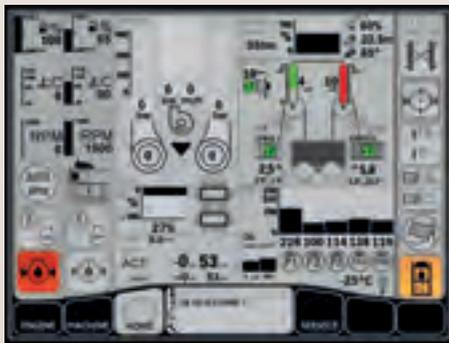

## Instrumentation

The verticality of the hydromill is constantly monitored by the control system and the corrections are applied by activating the flaps for directions X, Y and for the rotation on Z, or by selectively controlling the wheels on the X direction.

The FULL EXCAVATION FACE solution with the control instrumentation adopted allows an excavation verticality precision of more than 0.1% (e.g. for a 100 m deep diaphragm this means less than 100 mm deviation on the theoretical vertical).



## Measured and recorded data

- Deviation axis X, Y, Z
- Depth of excavation
- Cutting wheel speed
- Press. cutting wheel
- Speed of suction pump
- Flow of suction pump
- Hydromill weight on ground
- Min./Max. oil level compensator
- Two press. switches for chain tensioner
- Hydraulic oil contamination sensors



- 1 12" DISPLAY
- 2 HYDROMILL CONTROL PANEL
- 3 MONITORING AND RECORDING DEVICE



## Verticality of the Hydromill

All information on the orientation of the Hydromill and the deviation from the correct trajectory are shown on the control panel. The operator can correct the direction of excavation by using the controls of the steering plates. Each plate can assume four different positions. After having corrected the excavation trajectory, fully retract the guide plates.

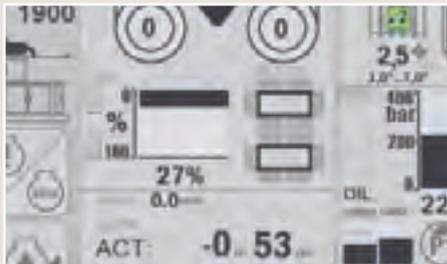

## Feed - selection of speed and direction

The load applied to the ground by the mills depend on ground conditions. The operator can control the feed (0-40 m/h). The load applied to the surface by the mill is indicated on the terminal by a percentage fraction of the weight of the Hydromill.

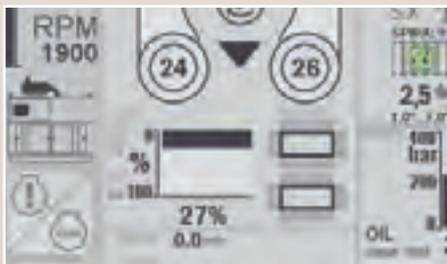

## Wheels

Selection of speed and direction is independent for each wheel, in order to control the verticality of the hydromill.

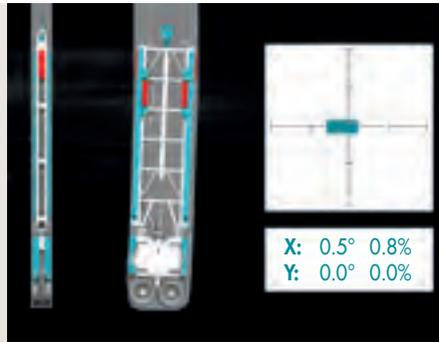
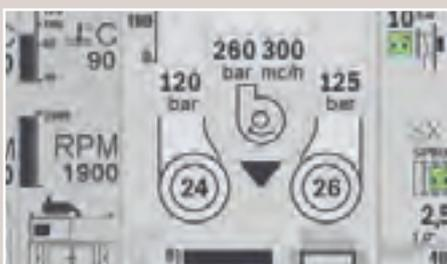

Verticality deviation along X-axis

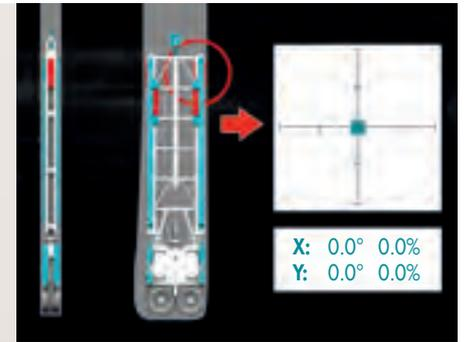

Activation steering plates for correction along X-axis



Verticality deviation along Y-axis

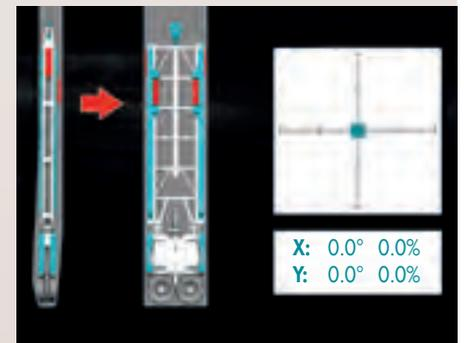

Activation steering plates for correction along Y-axis

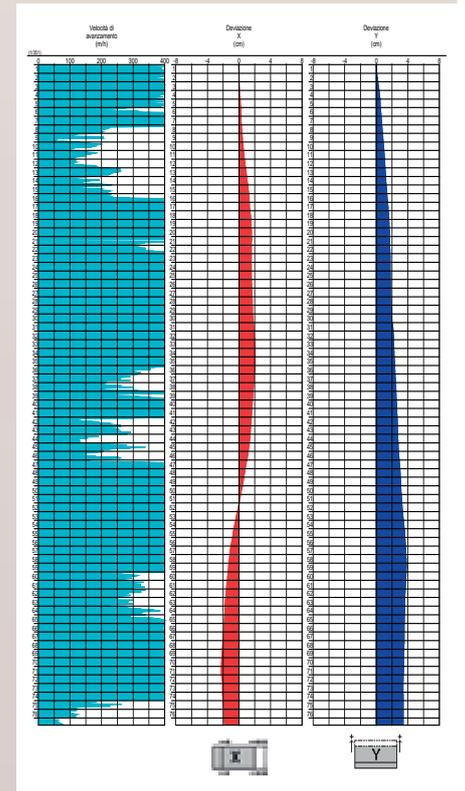
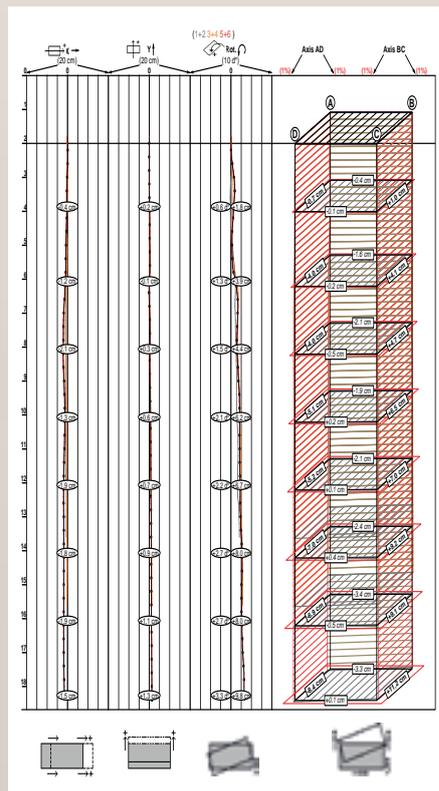

Example of output record

# BENTONITE TREATMENT PLANT

The desander plants are used to treat the slurries used for support in foundation engineering. The typical use is in excavation with hydromill or grabs in bentonite where the slurry from the excavation is treated in order to separate the soil from the bentonite.

Some plant solutions are available depending of geological features and layout of the job site:

- **D500** plant has one cycloning stage and is suitable for slurry with rocks, gravels and sands. The D500 can be completed with one additional desilter plant with secondary cycloning stage and desilter dewatering screen to increase the separation rate;
- **D500.500 + Desilter** plant has two cycloning stages and one additional desilter dewaterer screen is used to increase the separation rate of the soil from the bentonite. The plant is suitable for slurry with contents as clays and silts.

The plants are completed with "full package system", with access stairs and walkways, that gives the following benefits:

- reduced dimensions
- easy installation
- safe transport in a minimum number of package
- make available a minimum volume for desanded bentonite.



## DESANDER WITH FULL PACKAGE SYSTEM

		D500	D500.500 DESILTER
Nominal capacity	m <sup>3</sup> /h	500	500
Feed density	t/m <sup>3</sup>	1,18 – 1,2	1,18 – 1,2
Production of solids *	t/h	15 ÷ 200	15 ÷ 200
Separation	µm	60	30
Installed electrical power	kW	185	335
Overall dimensions	m	9 x 6,2 x 7,7	9 x 9,5 x 7,7
Approx dry weight	kg	33000	47000

\* Depending of particle size

# TYPICAL PLANT LAYOUT

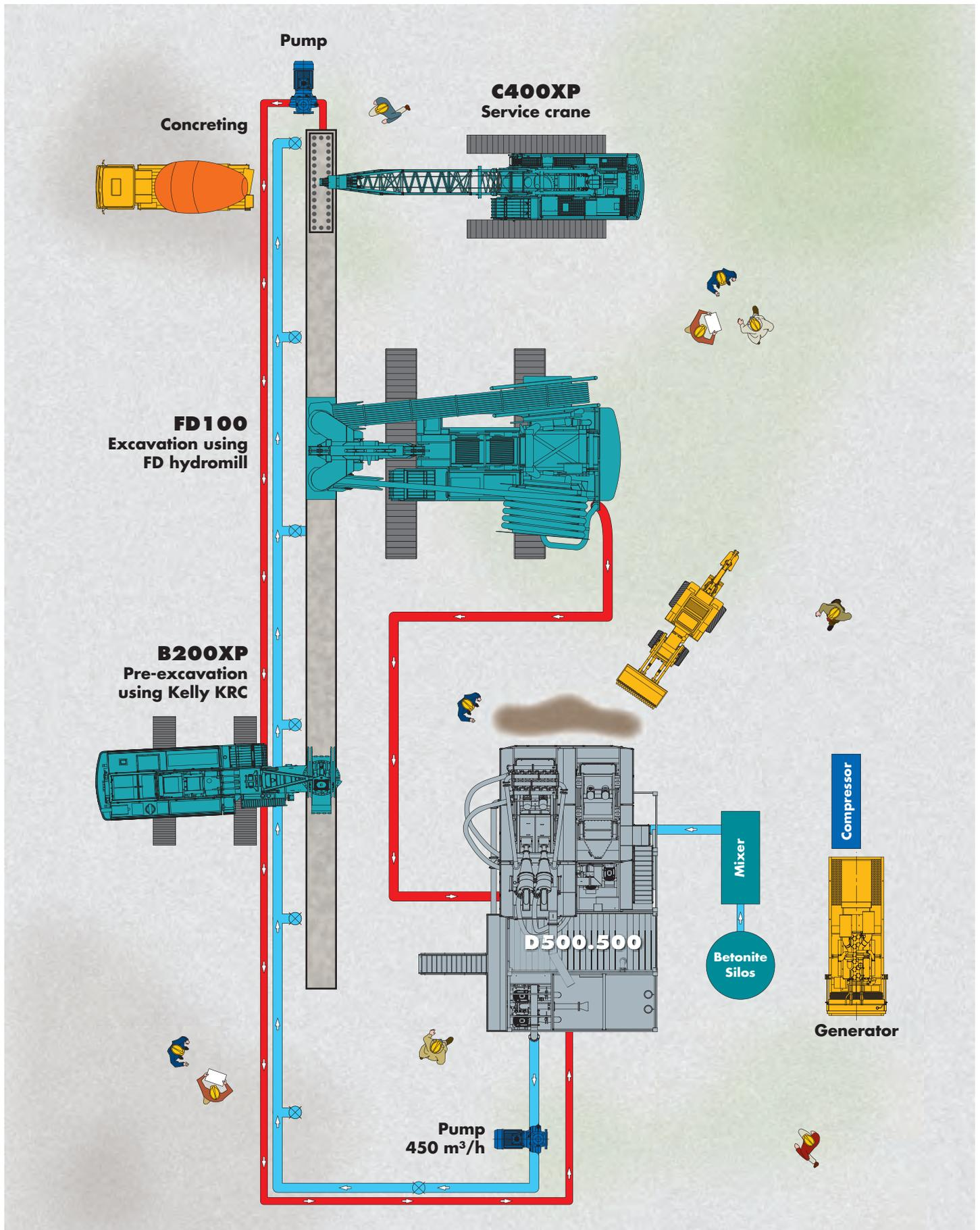

All data contained in this brochure are indicative and does not take power losses into account. All data can be changed without notice.  
Tutti i dati riportati su questo catalogo sono indicativi e non considerano perdite di carico. Tali dati possono variare senza preavviso.



**CASAGRANDE S.P.A.**  
Via A. Malignani, 1 • IT 33074 Fontanafredda • Pordenone • Italy  
Tel. (+39) 0434 9941 • Fax (+39) 0434 997009  
[www.casagrandegroup.com](http://www.casagrandegroup.com) • [info@casagrandegroup.com](mailto:info@casagrandegroup.com)

