

C5 ^{XP}

HYDRAULIC CRAWLER DRILL
PERFORATRICE IDRAULICA





THE C5XP represents the joint venture between over 50 years of Casagrande's experience in the field of drilling, together with the innovation a feature, which characterized the long history of company's successes.

LA C5XP rappresenta il connubio tra gli oltre 50 anni di esperienza di Casagrande nel campo della perforazione e l'innovazione, caratteristica che ha segnato la lunga storia di successi dell'azienda.



The C5XP is the multipurpose drill rig designed by Casagrande to perform projects in the field of foundation and is suited for constructing anchors and micropiles and jet grouting.

La C5XP è la macchina multifunzione ideata da Casagrande per l'esecuzione di opere di consolidamento e perforazione mediante la realizzazione di ancoraggi, micropali e jet grouting.

C5^{XP}

HYDRAULIC CRAWLER DRILL
PERFORATRICE IDRAULICA

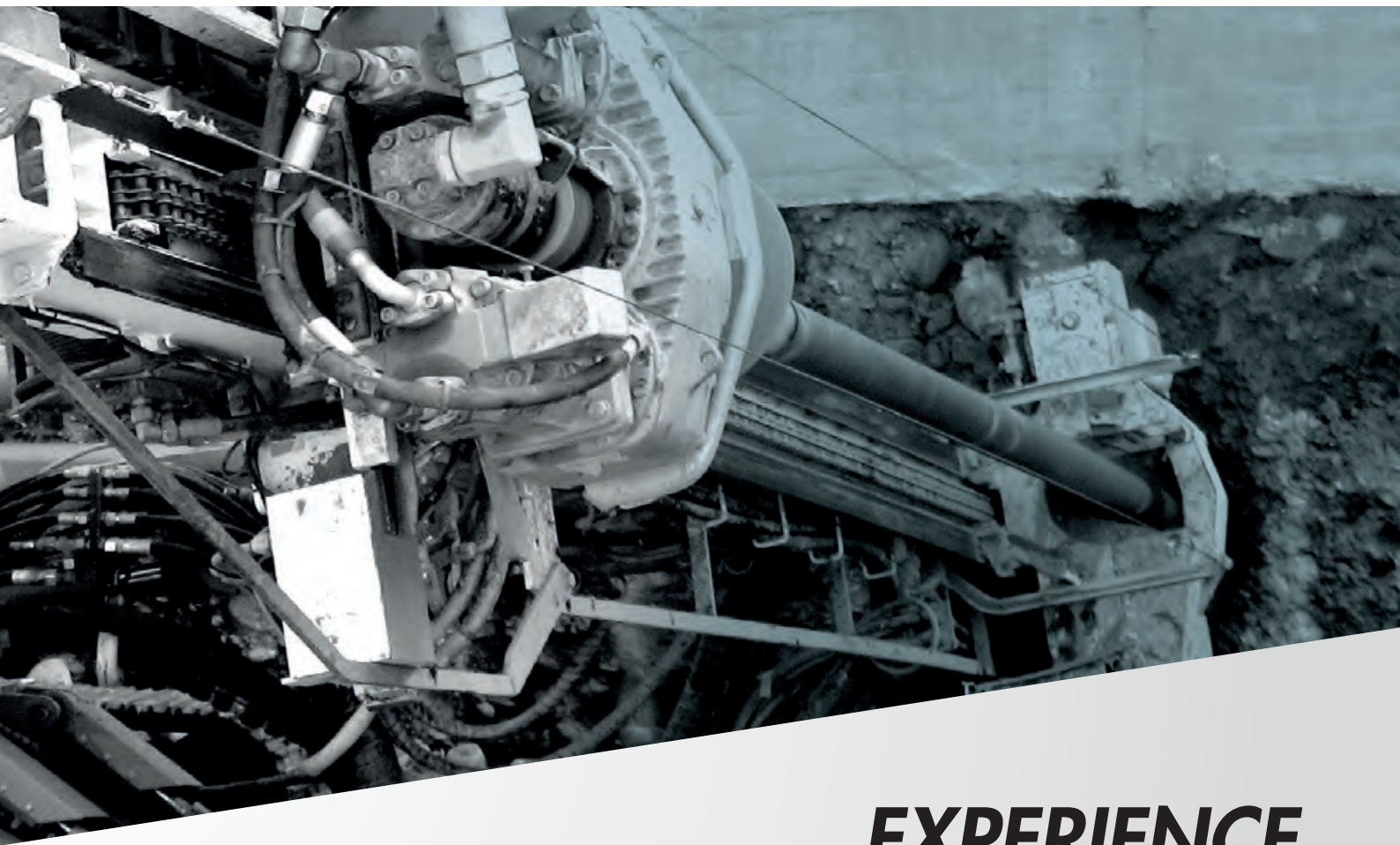

EXPERIENCE, PLUS, INNOVATION.

ESPERIENZA E INNOVAZIONE.



The SPM – Smart Power Management – and the full load sensing hydraulic system allow an intelligent engine power management to improve performance of the machinery and reduce fuel consumption.

Il sistema SPM – Smart Power Management – di gestione potenza e l'impianto idraulico Full Load Sensing permettono l'uso ottimale della potenza del motore e la riduzione dei consumi.



The crawler rig is equipped with modular mast, articulation with "Front The Wall" joint. It is such small and easy-to-use so that it can work in narrow spaces such as tunnels or inside buildings. The new C5XP is a compact crawler drill rig, easy to truck and maneuver thanks to the ergonomic remote control and the handy console on board.

Le dimensioni ridotte, il mast modulare, l'articolazione con snodo "Front The Wall" rendono la macchina adatta all'impiego in spazi limitati come all'interno di gallerie o di edifici. La C5XP è facile da manovrare grazie all'ergonomico radiocomando e alla pratica consolle di comando a bordo macchina.

CLAMP UNIT M2Z/M2SZ MORSE M2Z/M2SZ

Clamping force 145 kN – diameter 40 ÷ 254 mm
Forza di chiusura 145 kN – diametro 40 ÷ 254 mm

FRONT THE WALL JOINT ARTICOLAZIONE FRONT THE WALL

Continuous movements +/- 95°
Ampia movimentazione +/-95°

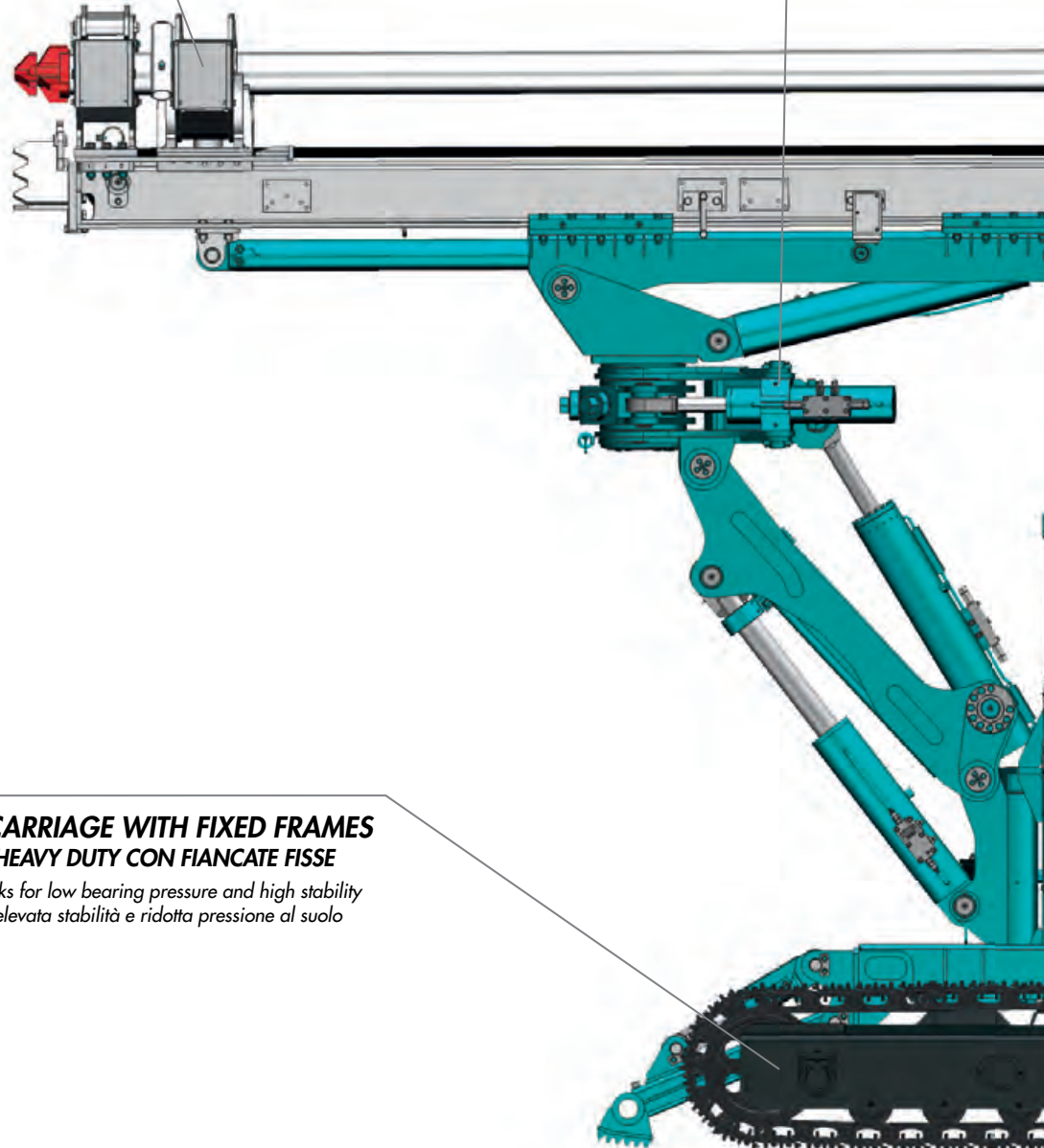

HD UNDERCARRIAGE WITH FIXED FRAMES SOTTOCARRO HEAVY DUTY CON FIANCATE FISSE

Long and wide tracks for low bearing pressure and high stability
Grandi cingoli per elevata stabilità e ridotta pressione al suolo

OPTIONS / OPZIONI



Option, rotary head T20 EP
torque 15,21 kNm – speed 360 rpm
Opzione, testa T20 EP
Coppia 15,21 kNm – velocità 360 rpm



Option, extendable tracks width 1600-2200 mm
for easy access in narrow spaces
Opzione, cingoli allargabili 1600-2200 mm
per accesso in spazi ristretti

**HEAVY DUTY MODULAR MAST
MAST MODULARE HEAVY DUTY**

Extraction force 50 kN, stroke of single rotary head up to 3.5 m
Forza di estrazione di 50 kN, 3,5 m corsa testa singola

**"EP" ROTARY HEAD WITH ELECTRO-PROPORTIONAL
CONTROL OF DISPLACEMENT**

**TESTA DI PERFORAZIONE CON CONTROLLO "EP"
ELETTO-PROPORZIONALE DELLA CILINDRATA**

It is possible to define different settings according to the requirement of the job site or of the operator's requests

È possibile definire differenti settaggi in funzione delle necessità del cantiere e delle richieste dell'operatore

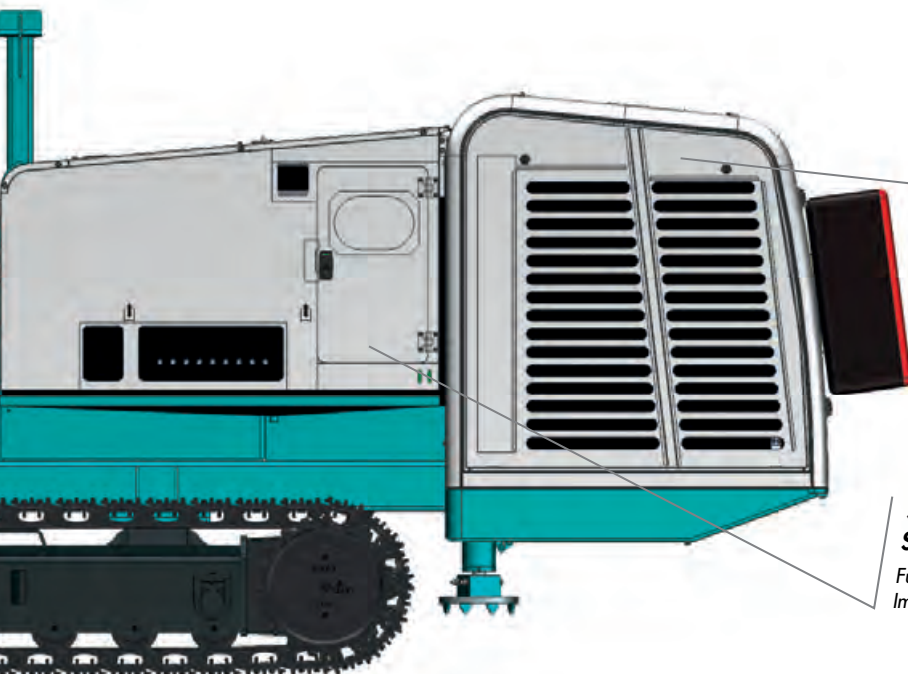
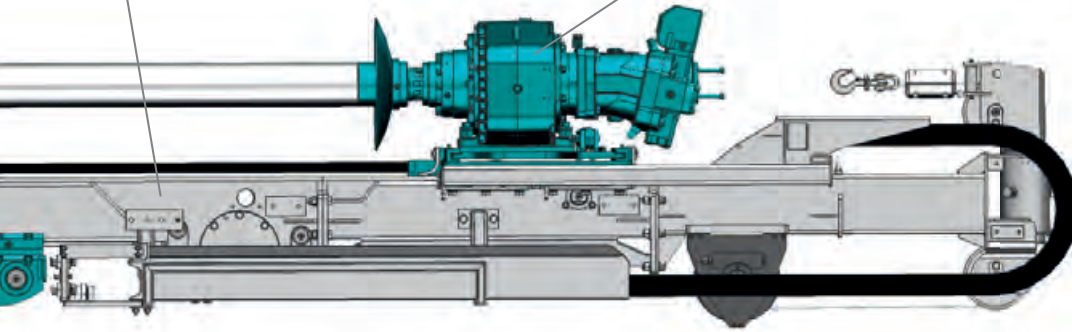

**POWERFUL DIESEL ENGINE
MOTORE DIESEL AD ELEVATA POTENZA**

Rated power 85 kW at 2200 rpm
Potenza di taratura 85 kW a 2200 rpm

**SPM - SMART POWER MANAGEMENT SYSTEM
SPM - SMART POWER MANAGEMENT SYSTEMS**

Full load sensing hydraulic
Impianto idraulico full load sensing



Option, drifter HB35A application
Opzione, testa a rotopercolazione HB35A



**Option, jet grouting arrangement
for 12 m treatment in single passage**
Opzione, allestimento jet grouting per trattamento
di 12 m in singolo passaggio

PERFORMANCE AND PRODUCTIVITY

PRESTAZIONI E PRODUTTIVITÀ



The Smart Power Management (SPM) is an intelligent engine power management system that improves performances and productivity of the machinery. The SPM system monitors the momentary power flows and immediately allocates the available power to the different jobs, so the operation function has always the maximum power available.

Il sistema di controllo Smart Power Management (SPM) permette una gestione intelligente della potenza del motore, aumentando le prestazioni e la produttività delle macchine. Questo sistema SPM monitora i flussi di potenza istantanei e destina in tempo reale la piena potenza disponibile alle funzioni di lavoro, affinché la funzione di lavoro abbia sempre a disposizione la massima potenza possibile.

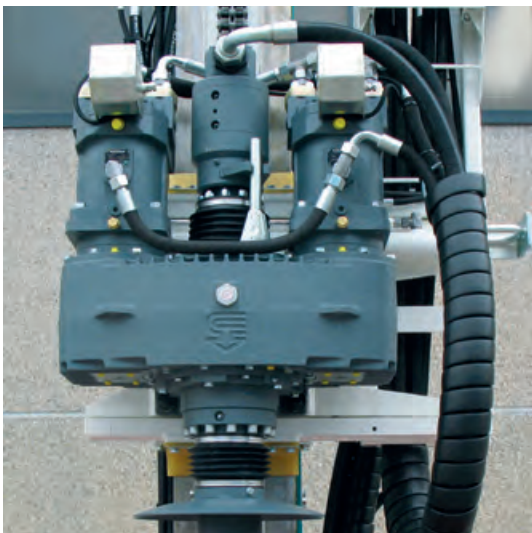

FULL LOAD SENSING TECHNOLOGY

TECNOLOGIA FULL LOAD SENSING



The XP hydraulic power system uses the Full Load Sensing (FLS) technology. Unlike the common hydraulic managing systems, the FLS pressurizes only the required amount of oil requested by users thanks to the back-action between pumps and distributors. It allows to manage the power demands and reduces dissipations, achieving up to the 25% of fuel saving (calculated on the basis of a theoretical working cycle).

Gli impianti idraulici di potenza di XP Series adottano la tecnologia Full Load Sensing (FLS). A differenza dei comuni sistemi di gestione idraulica, il sistema FLS, tramite una retroazione tra pompe e distributori, porta in pressione solo la quantità di olio richiesta istantaneamente dagli utilizzi. Ciò permette di gestire la richiesta di potenza e di ridurre le dissipazioni, ottenendo un risparmio di carburante fino al 25% (calcolato su un ciclo di lavoro teorico).



SAFETY & TECHNOLOGY

SICUREZZA E TECNOLOGIA



The C5XP has a very low sound emission level as a result of the use of sound-absorbing materials and smart oil heat exchangers where fan speed is related to the oil temperature reducing fuel consumption and the overall noise level.

The layout of the machine and the wide openings of the canopy offer comfortable and easy access for inspection and maintenance.

The machine conforms to the last international standards to guarantee the maximum safety of the operations.

La C5XP ha un ridotto impatto acustico grazie all'impiego di moderni materiali fonoassorbenti e all'impiego di scambiatore di calore intelligenti che regolano la velocità delle ventole in funzione della quantità di calore da dissipare.

L'intelligente disposizione dei componenti e le ampie aperture della carrozzeria offrono comodo e sicuro accesso per tutte le operazioni di ispezione e manutenzione.

La sicurezza delle operazioni di lavoro è garantita dal rispetto dei più stringenti standard internazionali.

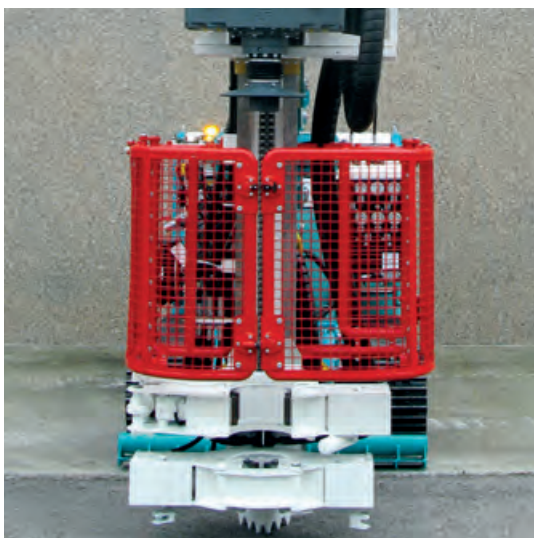

FLEXIBILITY

FLESSIBILITÀ



The XP control system offers the following advantages for the operator and the supervision of the work: monitoring of all working function, diagnostic of the working systems to ensure the constant monitoring of the status of sensors and components, easy conversion in any drilling arrangement, friendly customization of working functions e.g. mappings of torque and speed for EP rotary head, remote rigs assistance, diagnostic, monitoring of working parameters.

Il sistema di comando e controllo XP offre una serie di vantaggi per l'operatore: monitoraggio di tutte le funzioni di lavoro, diagnostica dei sistemi di lavoro per garantire il costante monitoraggio dello stato dei sensori e dei componenti. Facile e rapida conversione in diverse modalità operative, semplice personalizzazione delle funzioni di lavoro come mappatura del campo di coppia e velocità delle teste EP di perforazione, assistenza remota con diagnostica e monitoraggio dei parametri di lavoro.



DIESEL ENGINE	MOTORE DIESEL	
Diesel engine Stage 3A - Tier III	Motore diesel Stage 3A - Tier III	Deutz TCD 3.6 L04 – EDG
Rated power @ 2000 rpm	Potenza @ 2000 rpm	85 kW
Exhaust emission standard	Normativa emissioni	EU Stage 3A - US EPA Tier III
Diesel engine Stage 3B - Tier IVi	Motore diesel Stage 3B - Tier IVi	Deutz TCD 3.6 L04
Rated power @ 2000 rpm	Potenza @ 2000 rpm	85 kW
Exhaust emission standard	Normativa emissioni	EU Stage 3B - US EPA Tier IVi
Diesel tank capacity	Capacità serbatoio gasolio	100 l

HYDRAULIC SYSTEM	IMPIANTO IDRAULICO	
Hydraulic power	Potenza idraulica	70 kW
Hydraulic pressure	Pressione idraulica	350 bar
Main pump flow rate	Pompa principale portata	1 x 187 l/min
Auxiliary pumps flow rate	Pompe ausiliarie portata	2 x 44 l/min
Hydraulic oil tank capacity	Capacità serbatoio olio idraulico	300 l

UNDERCARRIAGE	SOTTOCARRO	B0
Undercarriage width	Larghezza sottocarro	1800 mm
Width of triple grouser track shoes	Larghezza pattini a tre barre	300 mm
Overall tracks length	Lunghezza cingoli	2380 mm
Travel speed	Velocità traslazione	0 - 2,2 km/h
Traction force - nominal	Forza di trazione - nominale	92 kN

MAST	MAST	3000MR*	5000MR*	4000 MR
Mast length	Lunghezza mast	3000 mm	5000 mm	4000 mm
Stroke of rotary head	Corsa testa di rotazione	1500 mm	3500 mm	2500 mm
Extraction / Crowd force	Forza Estrazione / Spinta	50 kN	50 kN	50 kN
Extraction / Crowd speed	Velocità Estrazione / Spinta	37 (78)* m/min	37 (78)* m/min	37 (78)* m/min

* Option
Opzione

CLAMPS	MORSE	M2Z M2SZ	MM2 MM2S
Diameter	Diametro	40 ÷ 254 mm	40 ÷ 159 mm
Clamping force	Forza di chiusura	145 kN	145 kN

ROTARY HEAD	TESTA DI ROTAZIONE	T 14 EP	T 12 2V
Max. torque	Coppia max.	12170 Nm	7200 Nm
Max. speed	Giri max.	57 ÷ 440 rpm	80 ÷ 160 rpm

DIMENSIONS

DIMENSIONI

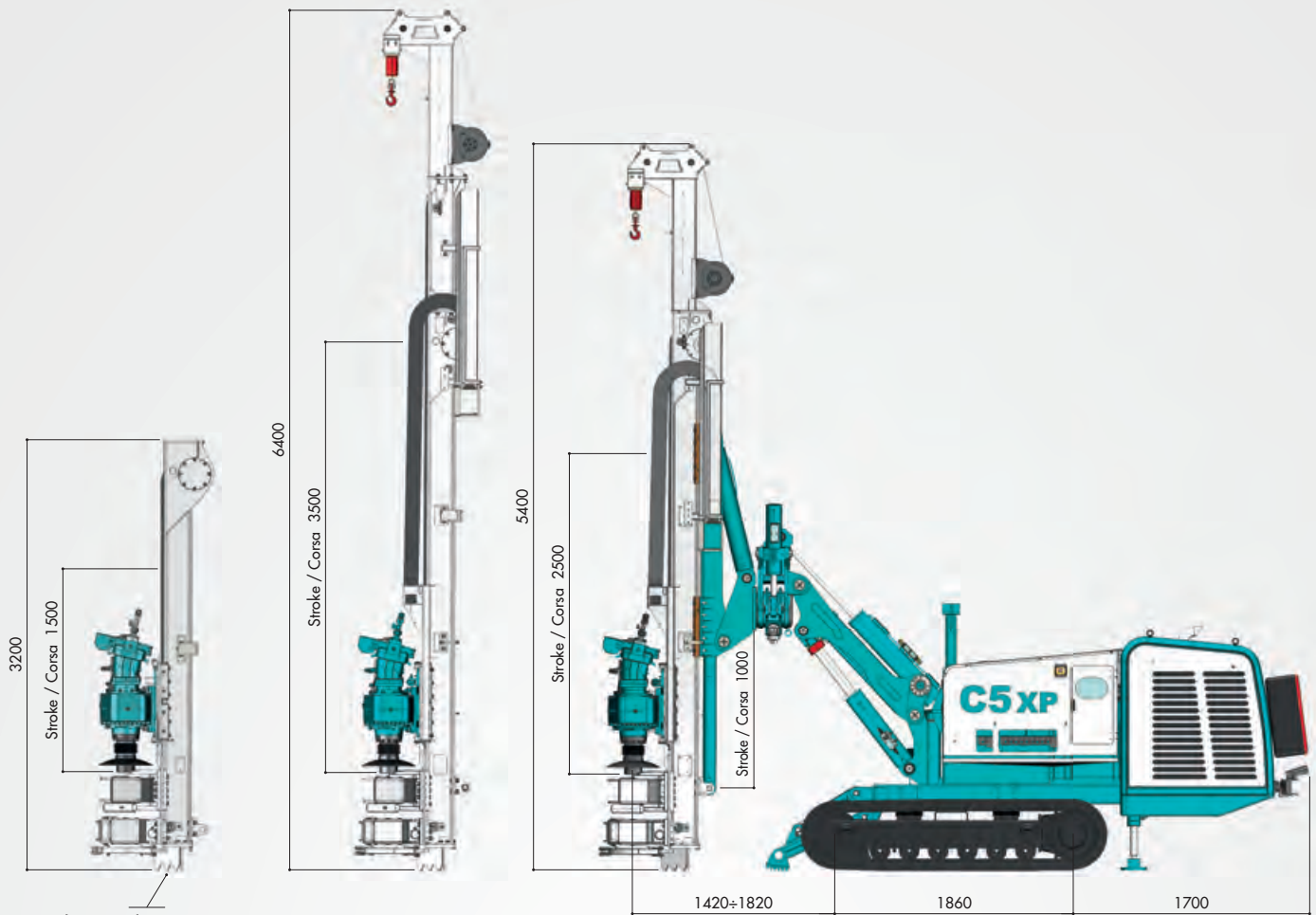

With special Kinematics
 Allestimento con articolazione speciale

TRANSPORT DATA

DATI DI TRASPORTO

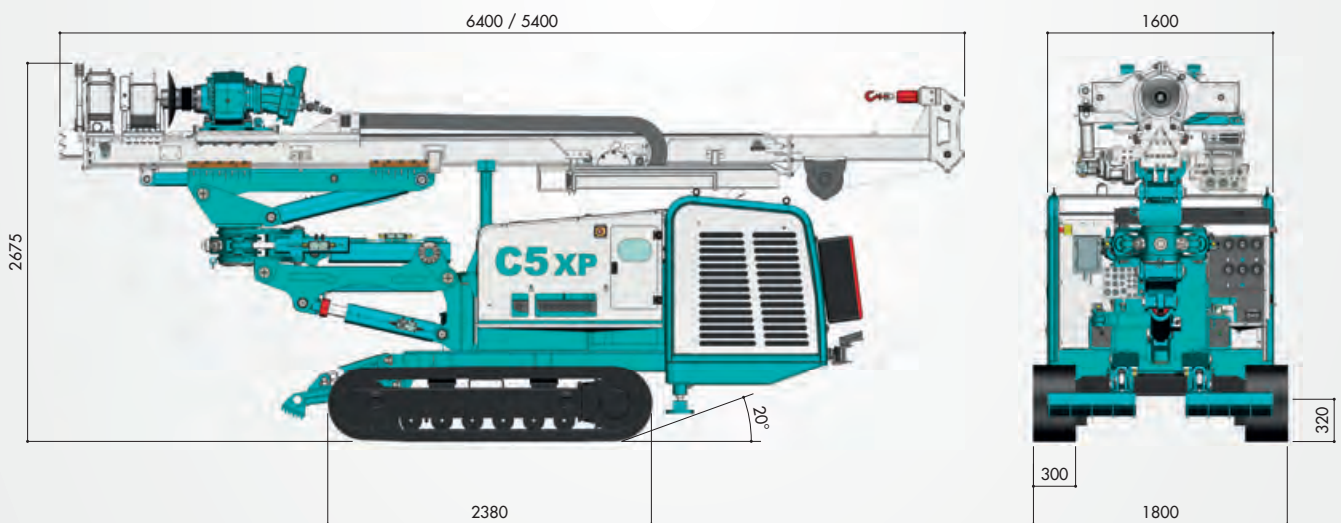

Weight of rig (depending of mounted equipment)
 Peso attrezzatura (dipende dall'allestimento montato)
 ~8500 kg

FRONT THE WALL KINEMATICS

ARTICOLAZIONE FRONT THE WALL



The heart of motions is therefore the joint system, studied to support all the stresses and to be operated within the most demanding conditions.

Through the control panel, the machine can be moved of +/- 95°. Thanks to its joints system, the C5XP is a fast and rapid machine to operate, easy to use. Total flexibility is the key word. The new joints system of the C5XP allows reaching the most extreme spots and can easily work in narrow spaces such as tunnels or inside buildings

Il cuore delle movimentazioni è la sua articolazione, studiata per sopportare tutte le sollecitazioni e lavorare nelle condizioni più impegnative.

Tramite il pannello di controllo la macchina può essere movimentata di +/- 95°. Grazie ad essa, la C5XP è una macchina rapida e veloce da mettere all'opera, semplice da usare. Flessibilità totale è la parola d'ordine. Il nuovo sistema di articolazione della C5XP consente di raggiungere le posizioni più estreme e di renderla adatta all'impiego in spazi limitati come all'interno di gallerie o di edifici.

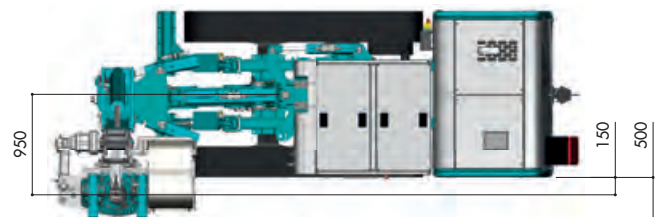

MAST MOVEMENTS

MOVIMENTAZIONI MAST

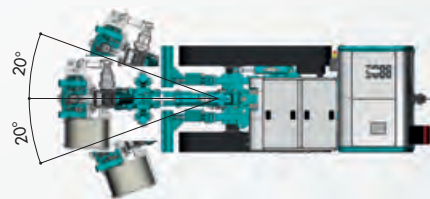
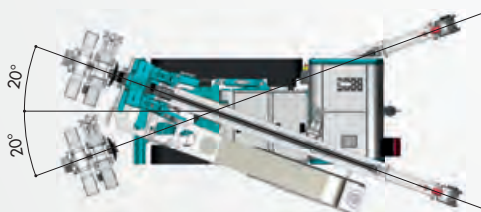
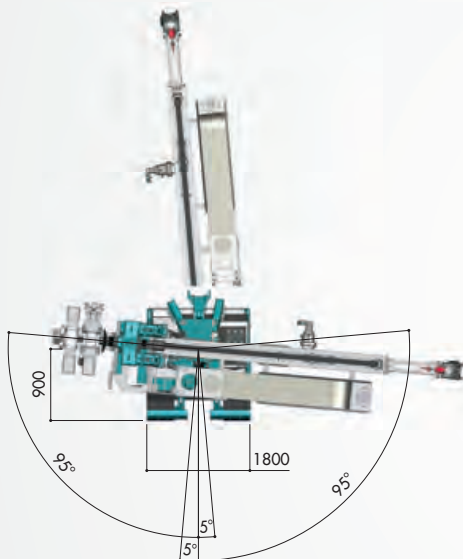
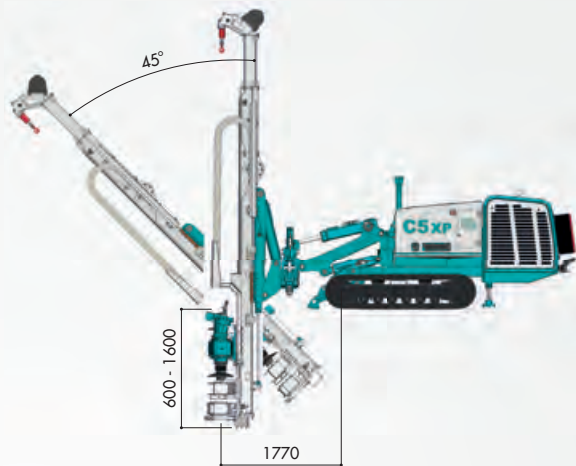
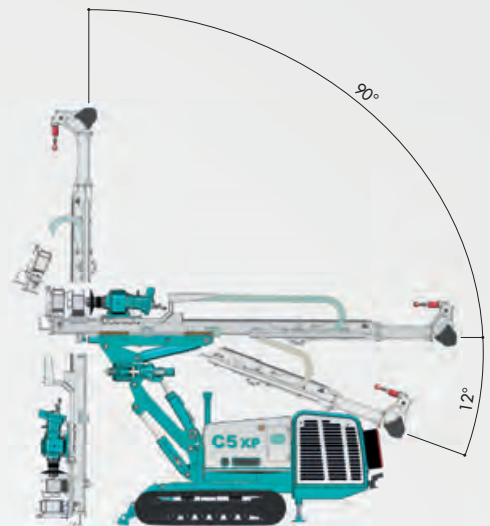
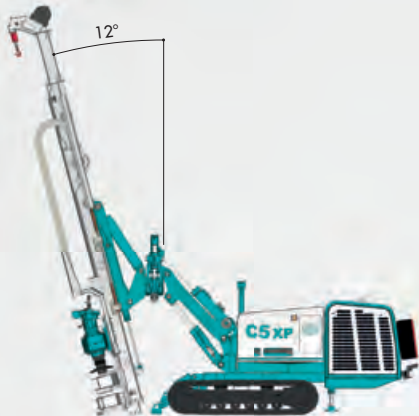

Rig movements are the maximum allowable. Any additional equipment on the rig may limit these movements.
 Movimentazioni massime consentite. Differenti allestimenti della perforatrice possono limitare queste movimentazioni.

JET GROUTING ARRANGEMENT ALLESTIMENTO JET GROUTING

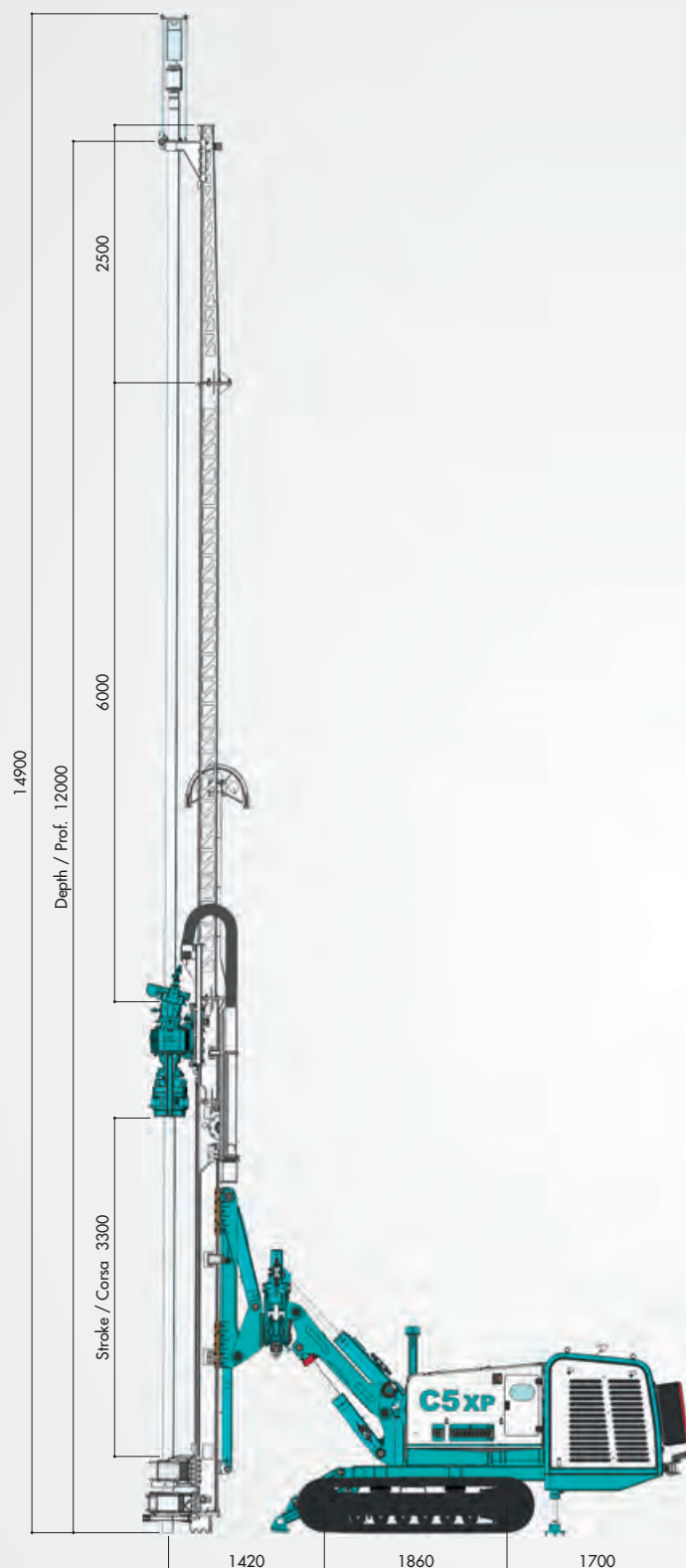





OPTIONS OPZIONI

> Hydraulic console	> Pannello controllo idraulico
> Other rotary heads available	> Altre teste di perforazione disponibili
> Drifter D21 / D21B (Back Device)	> Applicazione Martello D21 / D21B (Back Device)
> Rotary head side movement	> Spostamento laterale testa
> Hydraulic chuck type P114 for jet grouting	> Mandrino idraulico P114 per jet grouting
> Balancing kit – crowd/drilling feed	> Kit bilanciamento – spinta/velocità di perforazione
> Jet grouting system	> Impianto per jet grouting
> Auxiliary winch with rope Max line pull 900 kg	> Argano ausiliario completo di fune Tiro max. 900 kg
> Cathead for auxiliary winch	> Falchetto per argano ausiliario
> Flushing pump-Water pump GAMMA 62 (60 l/min max – 50 bar max)	> Pompa acqua GAMMA 62 (60 l/min max – 50 bar max)
> Foam pump C35 (30 l/min max - 50 bar max)	> Pompa schiumogeni C35 (30 l/min max - 50 bar max)
> Mud pump NG 530 L (170 l/min max - 24 bar max)	> Pompa fanghi NG 530 L (170 l/min max - 24 bar max)
> Lubricator for down-the-hole hammer 8,5 l	> Oliatore per applicazione martello fondo foro 8,5 l
> Electric fuel pump	> Pompa gasolio elettrica
> High pressure pump cleaner	> Idropulitrice
> Lifting kit	> Kit di sollevamento
> Cable remote control	> Filocomando
> Working lights	> Fari di lavoro
> Oscillating tracks	> Cingoli oscillanti
> Variable width track 1600/2200 mm	> Cingoli carreggiata variabile 1600/2200 mm
> Safety cages according to EN 16228	> Protezioni di sicurezza secondo EN 16228



**CASAGRANDE HYDRAULIC CRAWLER DRILLS RANGE
GAMMA PERFORTRICI IDRAULICHE CASAGRANDE**



C5^{XP}



C6^{XP}



C7^{XP}



C8^{XP}



C9^{XP}



C16^{XP}



CASAGRANDE S.P.A.

Via A. Malignani, 1
33074 Fontanafredda - Pordenone (Italy)

Tel. +39 0434 9941
Fax +39 0434 997009



info@casagrandegroup.com
www.casagrandegroup.com